

ITEM:	QUANTITY:	SPECIFICATION:
CONCRETE	0.13 CUBIC METERS	MIN. 27.6 MPa @ 28 DAYS
ADAPTOR PLATE	1	COMPOSITE MATERIAL, ANSI TIER 15 RATED, SLIP RESISTANT SURFACE
EMBEDDED ANCHORS	4	M12 x 50mm PLASTIC NC THREADED INSERT
SECURING SCREWS	4	M12-2.5 x 75mm STAINLESS STEEL, TAMPER RESISTANT, BUTTON HEAD

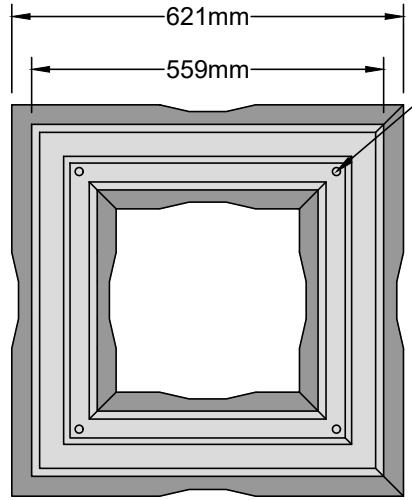

**PRODUCT TOP VIEW**

NTS

EMBEDDED ANCHOR POINT (4 THUS)

APPROX. BOLTING AREA = 330mm x 330mm

SECURING SCREW LOCATION (4 THUS)

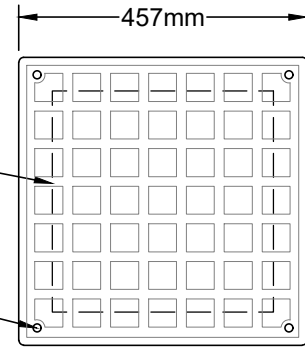

**ADAPTOR PLATE DETAIL**

NTS

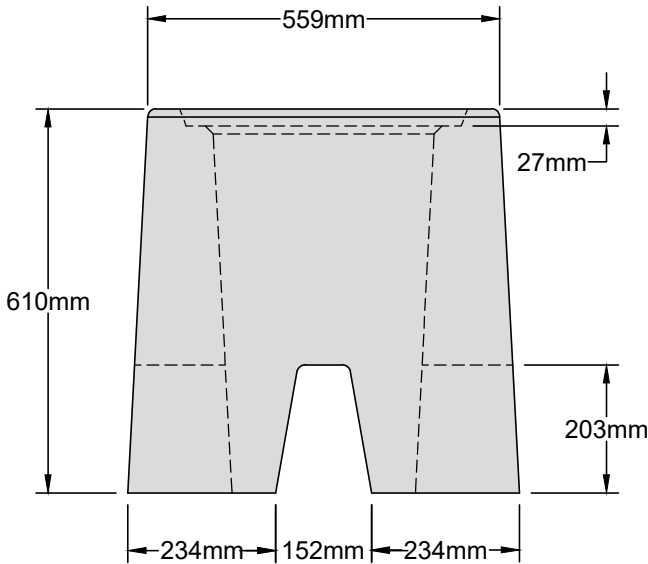

**PRODUCT SIDE VIEW**

NTS

APPROX. WEIGHT 295 kg

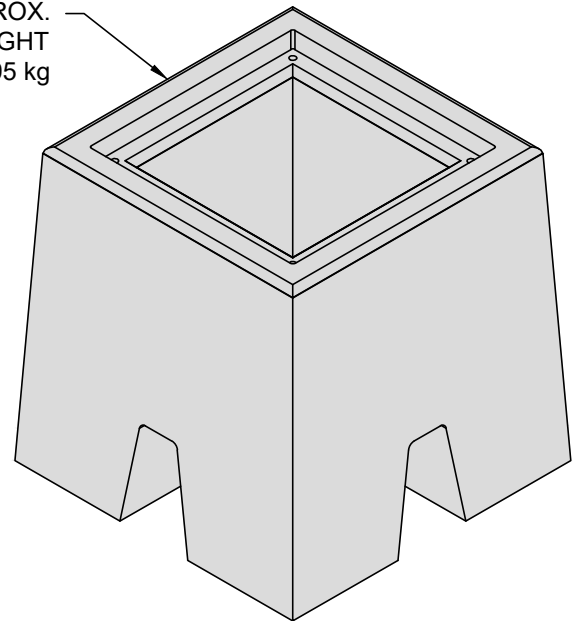

**PRODUCT ISO VIEW**

NTS

Disclaimer: This drawing has been prepared by EV Blocks, Ltd. and to the best of its knowledge, accurately represents the product use in the application that it is illustrated. Anyone making use of this drawing does so at their own risk and assumes all liability for such use. Final design for construction purposes must be completed by a Registered Professional Engineer who is familiar with the product and who has taken into account specific site conditions.

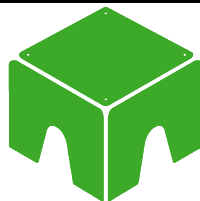

**EV BLOCKS.COM**

**EV BLOCK STANDARD  
PRODUCT TYP DETAIL**

EV BLOCKS - NORTH AMERICA

612.474.0089

evblocks.com/us

© Copyright 2023 EV Blocks, Ltd. All Rights Reserved